

# Micro Lenses for Imaging Systems

## Submillimeter components and complex compound elements

We combine all resources for your micro imaging needs under one roof!

### Your Benefits

- **One partner:** From design to prototyping to volume production, entire process under one roof.
- **Operational excellence:** To support high-precision optical and coating manufacturing processes.
- **Customized to needs:** Experts in custom optical build-to-print, build-to-spec and build-to idea solutions.
- **ISO13485 certificated:** Committed delivering optical components and systems with the highest reliability and quality meeting medical standards.

### Technical Data

- Smallest diameter of a component: 0.3 mm
- Surface finish: 5/2x0.01 according to DIN-ISO10110 or 10-5 according to MIL-PRF-13830B
- Irregularity down to:  $\lambda/6$
- Polish grade according P4
- Coating:
  - AR from 350 to 3000 nm
  - Mirrors (silver, aluminium, dielectric)
  - Bandpass filter
  - Black chrome

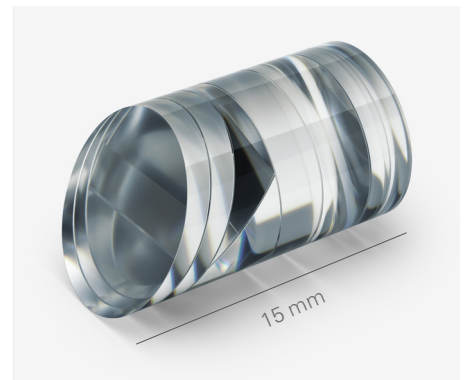

Subassembly with prism, lenses, aperture

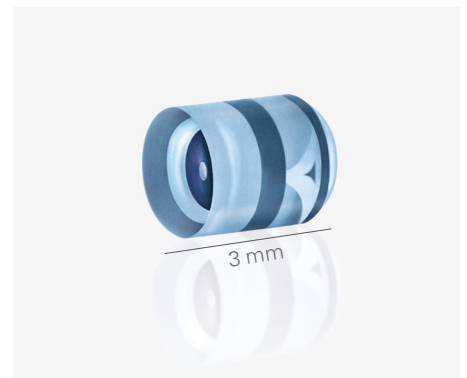

Cemented micro objective 3 mm



### Applications

- Endoscopy / Surgical Imaging
- Point of Care Devices
- Intra-oral Scanners
- Ophthalmology
- 3D Ear Scanners
- Machine Vision